



K NOZZLE METERS 500 PRESET

EN. Nozzle meter for oil. With the K500, the possibility to dispense in pre-selection mode is a unique feature of its kind. Once the pre-selected amount has been completed, the nozzle automatically closes the valve stopping the dispensing.

RU. Пистолет со счетчиком литров для масла. Возможность осуществлять подачу согласно предварительному выбору делает модель K500 уникальной в своем классе. После достижения выбранного количества, пистолет автоматически закрывает клапан и прекращает подачу.

DE. Literzähler-Zapfpistole für Öl. Die Möglichkeit zur Durchführung von Abgaben mit Voreinstellung macht K500 einzigartig. Wurde die voreingestellte Menge erreicht, schaltet die Zapfpistole automatisch ab.

PERFORMANCE

- Flow rates 1 - 30 l/min.
- Accuracy: +/- 0.5 %
- Repeatability: 0.2 %
- Viscosity 5 - 2000 cSt
- Max. pressure: 70 bar
- Min. preselectable quantity 0.1 litres, max. 99.9 litres
- Indication of the quantity dispensed with diver - if unit of measurement

- Расход от 1 до 30 л/мин.
- Погрешность: +/- 0,5 %
- Повторяемость: 0,2%
- Вязкость от 5 до 2000 сСт
- Макс. давление: 70 бар
- Возможность предварительного выбора количества от 0,1 литра до 99,9 литров
- Отображение поданного количества в разных единицах измерения

- Durchflussmenge 1 - 30 l/Min.
- Abgabegenauigkeit: +/- 0,5 %
- Wiederholbarkeit: 0,2 %
- Viskosität 5 bis 2000 cSt
- Max. Druck: 70 bar
- Voreinstellbare Menge mind. 0,1 l, max. 99,9l
- Anzeige der abgegebenen Menge in verschiedenen Maßeinheiten

DIMENSIONS

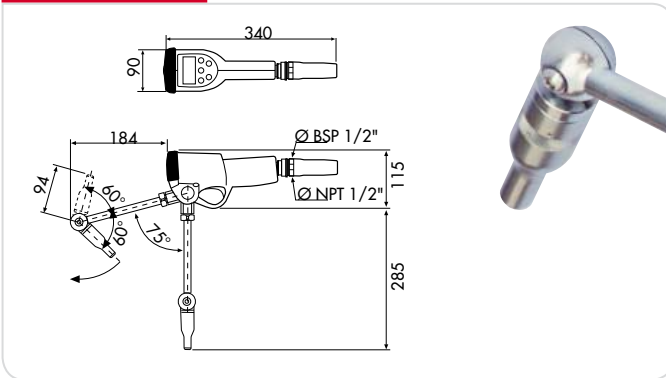

PATENTED



PRODUCTS' RANGE WEIGHT AND PACKAGING

Code	Weight		Packaging		
	kg	lbs	mm	inch	pcs/box
F0068700C	1,8	4	280x160x140	11x6,3x5,5	1
F00687200	1,8	4	280x160x140	11x6,3x5,5	1
F00687210	1,8	4	280x160x140	11x6,3x5,5	1
F0068600C	1,8	4	280x160x140	11x6,3x5,5	1

Flow-rate
up to
30 l/min
(up to 7,8 gpm)

Accuracy
+/-
0,5 %

Viscosity
up to
2000 cSt



ACCESSORIES

Rigid spouts:

B/P
Code **FOO676080**



Flexible spouts:

B/P
Code **FOO676070**



LF
Code **FOO676040**



A/P
Code **FOO676060**



HF
Code **FOO676050**



FEATURES



PRODUCTS' RANGE TECHNICAL DATA

Code	Description	Fluids type	Spout type	automatic no drip valve	Flow-rate		Pressure		Batteries size 1,5 V AA no.	Inlet
					l/min	gpm	bar	psi		
F0068700C	K500 w/articulable spout	☉	A	YES	1 ÷ 30	0,26 ÷ 7,8	70	994	4	1/2" BSP
F00687200	K500 w/rigid spout	☉	C	YES	1 ÷ 30	0,26 ÷ 7,8	70	994	4	1/2" BSP
F00687210	K500 w/flexible spout	☉	B	YES	1 ÷ 30	0,26 ÷ 7,8	70	994	4	1/2" BSP
F0068600C	K500 w/articulable spout	☉	A	YES	1 ÷ 30	0,26 ÷ 7,8	70	994	4	1/2" NPT