

SPECIAL EQUIPMENTS CAMBIAOLIO



EN. The “Cambialio” satisfies the ever-increasing demand of extracting used oil from cars directly through the dipstick holder. Trailer-mounted support. Self priming pump.

RU. Устройство “Cambialio” отвечает становящейся все более актуальной потребности в откачивании отработанного масла автомобиля непосредственно из гнезда щупа для проверки уровня масла. Опора с тележкой. Самозаливающийся насос.

DE. “Cambialio” wird der stets häufigeren Anforderung gerecht, dass Altöl von Fahrzeugen direkt durch das Rohr des Messstabes angesaugt werden muss. Fahrbarer Träger. Selbstansaugende Pumpe.

PERFORMANCE

- Continuous operation.
- Noise less than 70 dB.

- Непрерывное функционирование
- Уровень шума ниже 70 дБ

- Für Dauereinsatz
- Geräuschpegel geringer als 70 dB

DIMENSIONS

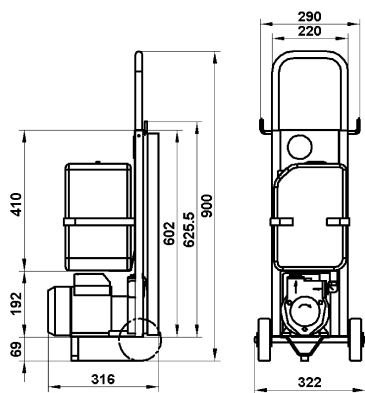

PRODUCTS' RANGE WEIGHT AND PACKAGING

Code	Weight		Packaging		
	kg	lbs	mm	inch	pcs/box
F0050000B	19,5	43	600x290x300	23,6x11,4x11,8	1
00050006A	19,5	43	600x290x300	23,6x11,4x11,8	1



Flow-rate

up to
10 l/min
(up to 3 gpm)

PIUSI[®]

EASY TO USE



INCLUDED

Probe Kit included:

- 1 semi-rigid probe Ø 6 x 800 mm
- 1 semi-rigid probe Ø 8 x 800 mm
- 1 rigid probe Ø 8 x 650 mm
- 1 rigid probe Ø 9 x 650 mm



Cambialio



FEATURES

Pressure Gauge



Tank 12 liter



On/off switch



PRODUCTS' RANGE TECHNICAL DATA

Code	Description	Fluids type	Flow-rate		Voltage			Tank	
			l/min	gpm	AC V./Hz DC Volt	Power Watt	Amp. max.	liter	gal
F0050000B	Cambialio M	☐	2 - 10	0,5 - 2,5	230/50-60	350	2	10	3
00050006A	Cambialio 120V / 60 Hz	☐	2 - 10	0,5 - 2,5	120/60	1200	12,7	10	3

DISPENSERS

PUMPS

METERS

NOZZLE
METERS

NOZZLE

SPECIAL
EQUIPMENTS

FLUID
MONITORING

ACCESSORIES

FILTERING