

ACCESSORIES COUPLING AND FITTINGS

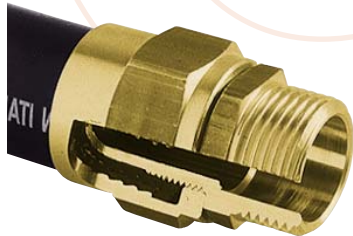

PRODUCTS' RANGE

Union
re-usable coupling



| Code | Description | Inlet/Outlet | | | Key 1 | Key 2 |
|---------------|-------------|--------------|------|------|-------|-------|
| | | A BSP | B mm | C mm | | |
| Swivel | | | | | | |
| 000890000 | Union 34.27 | 3/4" | 19 | 27 | 38 | 38 |
| 000891000 | Union 1.27 | 1" | 19 | 27 | 31 | 31 |
| 000892000 | Union 1.35 | 1" | 25 | 35 | 38 | 38 |
| 000893000 | Union 34.32 | 3/4" | 19 | 32 | 31 | 31 |
| 000894000 | Union 1.32 | 1" | 19 | 32 | 38 | 38 |
| 000895000 | Union 1.38 | 1" | 25 | 38 | 38 | 38 |

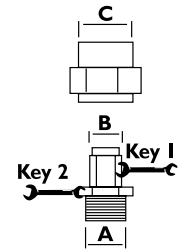

1



2



3



4

HQC
Hose Quick Coupling

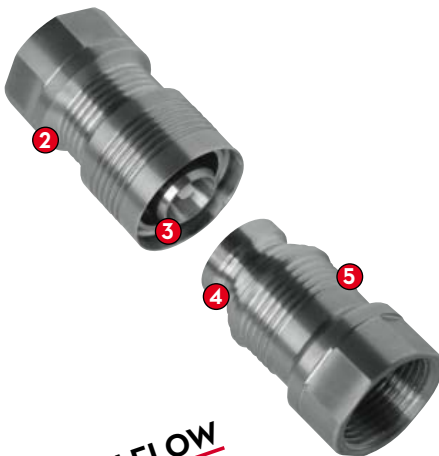

HIGH FLOW

EN. Hose quick coupling PIUSI has developed a new quick coupling that is suitable for use with diesel. In the past, quick couplings for use with diesel derived from quick couplings that were intended for use with oil, where the bores on the interior were too small for the diesel supply flow. With this quick coupling, this issue does not come into play. Here the bore has been designed to minimise resistance in the presence of high flow rates during the supply of the diesel.

- 1 - Fully closed position
- 2 - Open position
- 3 - Male coupling
- 4 - Female coupling
- 5 - Embossed profile: improves grip for coupling/uncoupling.

RU. Быстрое соединение для трубы Компания PIUSI разработала новое быстрое соединение, которое можно использовать с дизельным топливом. Ранее быстрые соединения для дизельного топлива создавались на базе быстрых соединений для масла, внутренний диаметр которых был недостаточно крупным для обеспечения подачи дизельного топлива. В свою очередь, внутренний диаметр этого быстрого соединения разработан с целью свести к минимуму сопротивление при высокой скорости потока дизельного топлива.

- 1 - Полностью закрытое положение
- 2 - Открытое положение
- 3 - Входящая часть соединения
- 4 - Охватывающая часть соединения
- 5 - Выпуклый профиль: улучшает захват при соединении и разъединении.

DE. Schlauch-Schnellkupplung PIUSI hat eine, zur Verwendung mit Diesel geeignete neue Schlauch-Schnellkupplung entwickelt. Einstige Schnellkupplungen für Diesel waren von Schnellkupplungen für Öl abgeleitet und deren innere Durchmesser waren nicht groß genug für den Durchfluss der Dieselabgabe. Nun wurde der Durchmesser dieser Schnellkupplung so entworfen, dass der Widerstand bei hohen Durchflüssen während der Abgabe von Diesel auf ein Minimum verringert ist.

- 1 - Position ganz geschlossen
- 2 - Position geöffnet
- 3 - Anschluss mit Außengewinde
- 4 - Anschluss mit Innengewinde
- 5 - Erhabenes Profil: Für besseren Griff beim Zusammenstecken-Herausziehen.

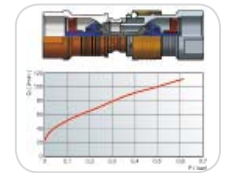

EN. Moulded internal profile: reduces pressure loss.

RU. Литой внутренний профиль: снижает потери напора.

DE. Inneres Formprofil: Reduziert den Strömungsverlust.

PRODUCTS' RANGE

| Code | Description | Weight | Pack. | Packaging |
|------------|----------------------------|--------|----------|-----------|
| | | Kg | pcs. no. | mm |
| HQC | | | | |
| F00636000 | HQC Hose Quick Coupling 1" | 0,46 | 1 | 80x80x75 |

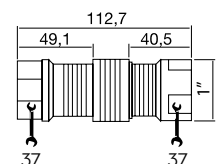

PRODUCTS' RANGE
Elbows

| Code | Description | A | B | Q.ty | Key |
|---------------|-------------|------------|------------|------|-----|
| Elbows | | | | | |
| F07806000 | | F 3/4" BSP | F 3/4" BSP | - | - |
| F07805000 | | M 3/4" BSP | F 3/4" BSP | - | - |
| F08609000 | | F 1" BSP | F 1" BSP | - | - |
| F07988000 | | M 1" BSP | F 1" BSP | - | - |
| F14279000 | Inox | M 1" BSP | F 1" BSP | - | - |

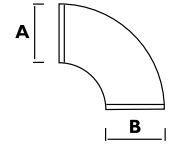
Hose tails

Inox Version

| | | | | | |
|-------------------|------|------------|-------|----|----|
| Hose tails | | | | | |
| F0826700A | | 1/2" BSP | 19 mm | 1 | 27 |
| F0643700A | | 3/4" BSP | 19 mm | 20 | 32 |
| F0776800B | | 3/4" BSP | 25 mm | 20 | 32 |
| F0775700A | | 1" BSP | 19 mm | 20 | 37 |
| F0776400A | | 1" BSP | 25 mm | 20 | 37 |
| F14122000 | Inox | M 1" BSP | 19 mm | 1 | 37 |
| F14123000 | Inox | F 3/4" BSP | 19 mm | 1 | 37 |

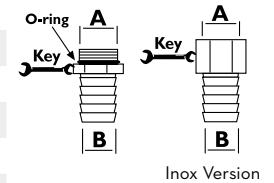

Inox Version

Rotating hose tails - Inox

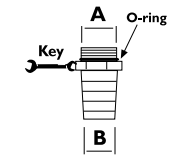

| | | | | | |
|----------------------------------|------|----------|-------|---|----|
| Rotating hose tail - Inox | | | | | |
| F14132000 | Inox | 3/4" BSP | 19 mm | - | 27 |

Sleeve

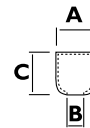

| | | | | | |
|---------------|--|-------|-------|---|----|
| Sleeve | | | | | |
| F08137000 | | 28 mm | 20 mm | - | 30 |
| F08138000 | | 36 mm | 28 mm | - | 35 |

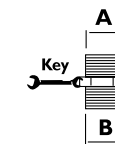
Sleeve

| | | | | | |
|---------------|--|------------|------------|---|----|
| Sleeve | | | | | |
| F07766000 | | M 3/4" BSP | M 3/4" BSP | - | 27 |
| F07765000 | | M 1" BSP | M 1" BSP | - | 34 |

Reducing sockets

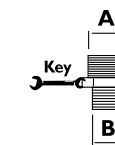
| | | | | | |
|-------------------------|--|------------|--------------|---|----|
| Reducing sockets | | | | | |
| F07441000 | | F 1/2" BSP | M 3/4" BSP | - | 30 |
| F07762000 | | M 3/4" BSP | M 1" BSP | - | 34 |
| F08913000 | | M 1" BSP | M 1 1/2" BSP | - | 50 |
| F07760000 | | F 3/4" BSP | M 1" BSP | - | 35 |
| F07889000 | | F 1" BSP | M 3/4" BSP | - | 34 |
| 008891000 | | F 1" BSP | M 2" BSP | - | 60 |

Elbow rotating connector

M/1" BSP

 Code **F14567000**
Sealant paste

| Code | Description | | Q.ty |
|-----------|---------------------|---------|------|
| F08173000 | Light removable | g. 130 | 1 |
| F10767000 | Medium removable | ml. 250 | 1 |
| F12278000 | Heavy non removable | ml. 250 | 1 |

