



PIUSI AIR OPERATED MEMBRANE PUMP

PIUSI
®

Fluid Handling Innovation

O7.14

EN. The company

PIUSI was established in 1953 in Suzzara, in the province of Mantua (Italy). They started as a mechanical engineering workshop serving the agricultural industry. The company soon made a name for itself as a manufacturer of strong and easy-to-use products suitable for a range of "different uses" (più-usi).

The beating heart of PIUSI has always been its workers and just as this hard and generous land produced the company, so PIUSI provides stability and wealth to the area known as the thriving economic centre of Italy, with a deep-rooted presence in Suzzara. Research is constantly focused on finding innovative solutions, the upshot of the genius of Italian excellence. This has led PIUSI to set up modern offices and a manufacturing facility which includes an automated warehouse on a covered surface area of 25,000 m² (270,000 SqFt), part of a larger area covering 44,000 m² (473,000 SqFt). PIUSI boasts an efficient and dynamic corporate structure with 200 employees, an inhouse research & development laboratory, and an extensive sales and spare-parts network, further strengthened in 2009 with the opening of a company for the north and central American market based in Florida - USA. Today PIUSI spa is a major player in over 120 different countries, with a broad range of intelligent, professional and easy-to-use solutions for transferring and measuring fuels, lubricants and liquids, able to satisfy customer needs by carefully and competently listening to the Voice of the Customer.

ES. La Empresa

PIUSI se funda en el año 1953 en Suzzara (provincia de Mantova), como taller mecánico para aplicaciones agrícolas destaca por sus productos resistentes y fáciles de usar, idóneos para varios usos de ahí su nombre en italiano PIU' - USI (varios usos).

Desde siempre el motor de PIUSI son las personas que trabajan en ella y al igual que esta tierra dura y generosa ha dado sus orígenes a la empresa, PIUSI recompensa con estabilidad y riqueza el territorio, mediante su presencia consolidada en Suzzara, centro neurálgico de la economía italiana.

La investigación constante para proporcionar soluciones innovadoras, fruto del ingenio de la excelencia italiana, ha desembocado para PIUSI en la realización de un área productiva, un almacén automatizado y oficinas modernas que ocupan 25.000 m² de un área de 44.000 m². PIUSI posee una estructura empresarial, eficiente y dinámica, compuesta por 200 empleados, un laboratorio interno de investigación y desarrollo, una red comercial y de recambios ramificada, que se potenció en 2009 aún más con la apertura de una sociedad para el mercado americano del norte y del centro, ubicada en Florida (Estados Unidos).

Actualmente, PIUSI spa es una empresa afirmada, presente en más de 120 países, con una amplia gama de soluciones inteligentes, de calidad profesional y fáciles de usar para el transvase y la medición de carburantes, lubricantes y líquidos, que satisfacen las exigencias del cliente a través del seguimiento atento y competente del mercado.

PT. A Empresa

PIUSI foi fundada em 1953 em Suzzara na província de Mântua, como uma oficina mecânica para aplicações agrícolas. Desde o início a empresa destaca pela qualidade dos produtos: durável, fácil de usar, adequado para PIU'-USI, vários usos (que teve o seu nome).

Piusi riqueza desta terra atrai duro e generoso, e em vez disso oferece estabilidade e prosperidade no território de Suzzara, motor econômico da Itália.

Certamente, as pessoas são PIUSI centro, impulsionado pelo orgulho, paixão e do desejo de sucesso aos novos desafios.

A pesquisa constante para o resultado de soluções inovadoras de engenharia de excelência italiana, liderada PIUSI ser consolidado, que opera em mais de 120 países. A empresa oferece uma ampla gama de produtos inteligentes, de excelente qualidade e facilidade de uso para a transferência e medição de combustíveis, lubrificantes antes e fluidos. Produtos Piusi pode atender às necessidades dos clientes, através da escuta atenta e constante demanda do mercado.

A empresa ocupa uma área de 44.000 m², que é uma loja automatizada e escritórios modernos. PIUSI também tem estrutura empresarial eficiente e dinâmica de 200 empregados, pesquisa e desenvolvimento próprio laboratório, rede de vendas, que foi reforçada em 2009 com a abertura de uma filial na Flórida pelo mercado da América do Norte e Central.



EN. Piusi enters the world of air-operated pumps.

The Piusi MP and Piusi MA air-operated diaphragm pumps feature an air motor feeding inversion system (IAMA) that allows rapid tuning of pump speed and flow rate by adjusting the quantity of air supplied.

Piusi MP and Piusi MA pump quality is assured by an advanced level of technology and materials: the central body is made of polypropylene, the lateral half-shells and suction and delivery manifolds are in polypropylene (Piusi MP) or aluminum (Piusi MA), while the diaphragms are made to be stronger and more durable. The diaphragms, which are highly resistant to chemical aggression and mechanical stress, come in two varieties:

- diaphragm in thermoplastic material (Hytrel air side, PTFE liquid side), suitable for handling water and treatment of chemical liquids such as AdBlue, antifreeze or screenwash.
- diaphragm in nitrile rubber (NBR), suitable for handling oil, whether contaminated or new.

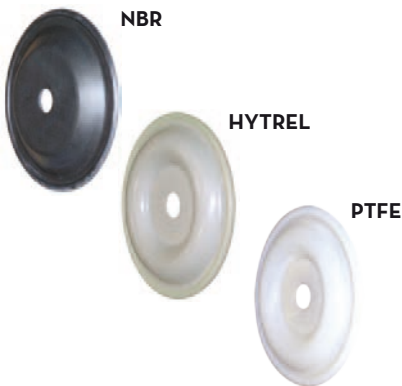

ES. Piusi entra en el mundo de las bombas neumáticas

Las bombas neumáticas de membrana Piusi MP y MA se caracterizan por el sistema IAMA (Inversión de Alimentación del Motor de Aire) que, mediante la regulación de la cantidad de aire introducida, permite calibrar rápidamente la velocidad y el caudal de la bomba.

La calidad de las bombas Piusi MP y MA está garantizada por la alta tecnología y por los materiales utilizados: el cuerpo central es de polipropileno, con los medios cuerpos laterales y los colectores de aspiración e impulsión en polipropileno (MP) o aluminio (MA).

- Las membranas tienen alta resistencia química y mecánica y se ofrecen en dos tipos:
- de material termoplástico (Hytrel lado aire, PTFE lado líquido), ideales para el agua y para líquidos químicos como AdBlue, anticongelantes o lavaparabrisas;
 - de goma de nitrilo (NBR), aptas para aceites nuevos y usados.

PT. A Piusi entra no mundo das bombas pneumáticas.

As bombas pneumáticas com membrana Piusi MP e Piusi MA são caracterizadas pelo sistema IAMA (Inversão da Alimentação do Motor de Ar) que através da regulação da quantidade de ar emitido, permite uma rápida calibração da velocidade e da carga da bomba. A qualidade das bombas MP e Piusi MA é garantida pela alta tecnologia e pelos materiais utilizados: o corpo central é de polipropileno, os semi-corpos laterais e os coletores de aspiração e descarga são em polipropileno (Piusi MP) ou em alumínio (Piusi MA), enquanto as membranas são em material de alta resistência. As membranas oferecem uma elevada resistência química e mecânica e têm dois tipos:

- membranas em material termoplástico (Hytrel do lado do ar, PTFE do lado do líquido), ideais para a água e para o tratamento de líquidos químicos como o AdBlue, o líquido anticongelamento ou o lava-vidros.
- membranas em borracha nitrílica (NBR) adequada para o óleo retirado, óleo.

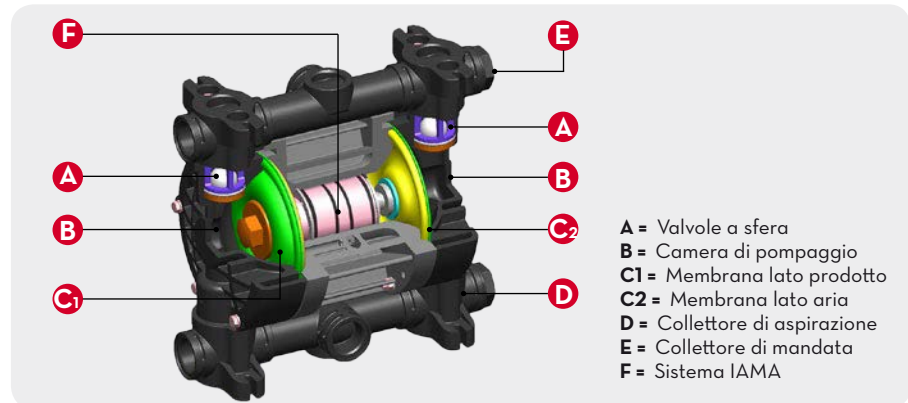

EN. How the Piusi MA/MP air-operated diaphragm pump works

The compressed air, which is injected through IAMA (air motor feeding inversion) system (1) creates a vacuum behind one of the two diaphragms thus allowing the fluid (2) to be drawn from the suction line. Simultaneously, the opposite membrane (which is connected to the system) forces the fluid to delivery line (3). When the cycle is concluded the IAMA system diverts the compressed air supply to the rear of the opposite diaphragm, and the sequence is repeated.

ES. ¿Cómo funciona una bomba neumática de membrana Piusi MA/MP?

El aire comprimido e introducido a través del sistema IAMA (Inversión de Alimentación del Motor de Aire) (1) crea una depresión detrás de una de las dos membranas que succiona el líquido (2) por el conducto de aspiración. Al mismo tiempo la membrana opuesta, conectada al sistema, empuja el líquido por el conducto de impulsión (3). Una vez completado el ciclo, el sistema IAMA desvía el aire comprimido hacia detrás de la membrana opuesta y la secuencia se repite.

PT. Como funciona a bomba pneumática com membrana Piusi MA/MP?

O ar comprimido, inserido através do sistema IAMA (Inversão de Alimentação do Motor de Ar) (1) cria uma depressão atrás de uma das duas membranas que permite aspirar o líquido (2) do conduto de aspiração. Simultaneamente, a membrana oposta, conectada ao sistema, empurra o líquido do conduto de descarga (3). Uma vez concluído o ciclo, o sistema IAMA desvia o ar comprimido atrás da membrana oposta e a sequência se repete.

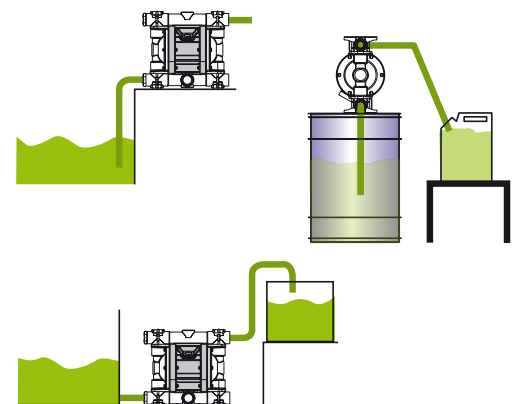
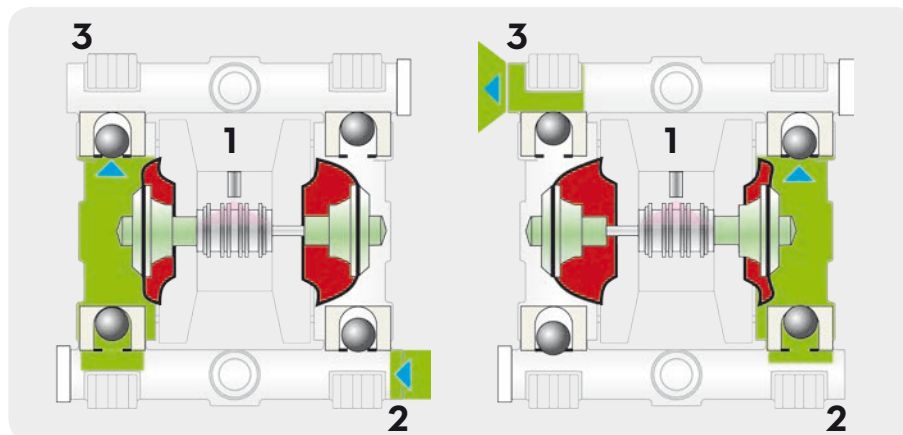



PIUSI MP

EN. PIUSI MP air-operated diaphragm pumps are designed to assure the utmost reliability and highest performance levels. The sturdy central technopolymer body, the suction, the lateral half-shells and delivery manifolds use the highest quality thermoplastic diaphragms. This diaphragm makes it possible to transfer water and chemicals such as AdBlue, antifreeze, and screenwash.

The pneumatic circuit is a guarantee of safety and the construction principle makes Piusi MP pumps particularly suitable for severe duty conditions or operation in potentially explosive atmospheres (ATEX certification for zone 2).

Piusi MP pumps are self-priming and can run dry without damage; they also allow fine tuning of speed without pressure loss.

ES. Las bombas neumáticas de membrana PIUSI MP garantizan máxima fiabilidad y altas prestaciones. El robusto cuerpo central de tecnopolímero, los medios cuerpos laterales y los colectores de aspiración e impulsión en polipropileno, junto con las membranas de alta calidad en materiales termoplásticos; permiten el trasiego de agua y de líquidos químicos como AdBlue, anticongelantes o lavaparabrisas.

Por la seguridad del circuito neumático y por su diseño avanzado, las bombas Piusi MP están especialmente indicadas para aplicaciones severas o atmósferas potencialmente explosivas (certificación ATEX para zona 2).

Las bombas Piusi MP son autocebantes, pueden funcionar en seco sin dañarse y permiten hacer una regulación precisa de la velocidad sin pérdidas de presión.

PT. As bombas pneumáticas com membrana PIUSI MP são projetadas para garantir a máxima confiabilidade e as prestações. O robusto corpo central em tecnopolímero, os semi-corpos laterais e os coletores de aspiração e descarga em polipropileno e a utilização de membranas de alta qualidade em materiais termoplásticos permitem a passagem de água, de líquidos químicos como o AdBlue, o líquido anticongelamento ou o lava-vidros.

O circuito pneumático é garantia de um funcionamento seguro e o princípio construtivo torna as bombas Piusi MP particularmente indicadas para a aplicação graves ou em ambientes potencialmente explosivos (certificação ATEX para zona 2).

As bombas Piusi MP são automáticas, podem funcionar a seco sem danos e permitem realizar uma regulação precisa da velocidade sem perdas de pressão.

DIMENSIONS

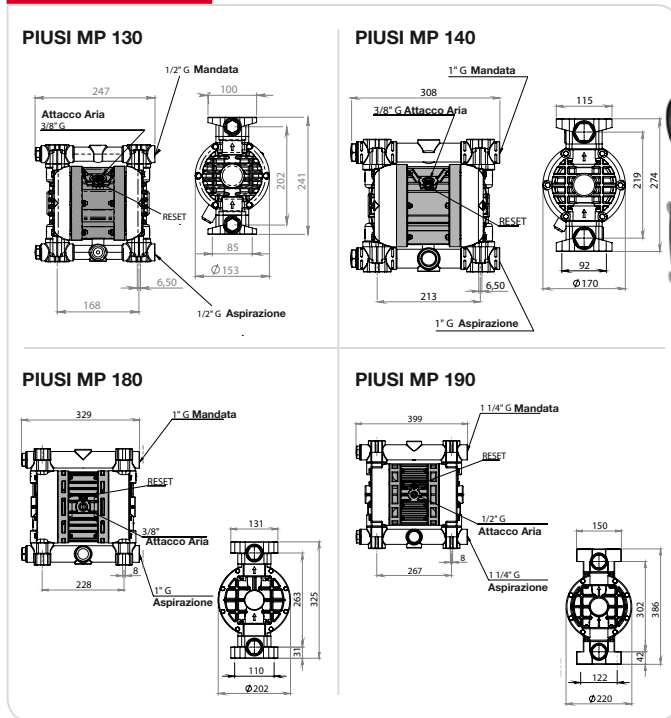

PRODUCTS' RANGE WEIGHT AND PACKAGING

Code	Weight		Packaging		
	kg	lbs	mm	inch	pcs/box
F00208P00	3,6	7,9	220x310x320	8,7x12,2x12,6	1
F00208P20	5	11	240x380x350	9,4x15x13,8	1
F00208P30	7,5	16,5	270x390x400	10,6x15,4x15,7	1
F00208P40	12	26,5	290x470x460	11,4x18,5x18,1	1

PRODUCTS' RANGE TECHNICAL DATA

Code	Description	Fluids	Pump Body	In/out	Flow Rate
		type			l/min
F00208P00	PIUSI MP130	WUA	Polypropylene	1/2" G	50
F00208P20	PIUSI MP140	WUA	Polypropylene	1" G	100
F00208P30	PIUSI MP180	WUA	Polypropylene	1" G	150
F00208P40	PIUSI MP190	WUA	Polypropylene	1" 1/4" G	220



Flow-rate
up to
220 l/min
(up to 58,1 gpm)



PIUSI MP 130

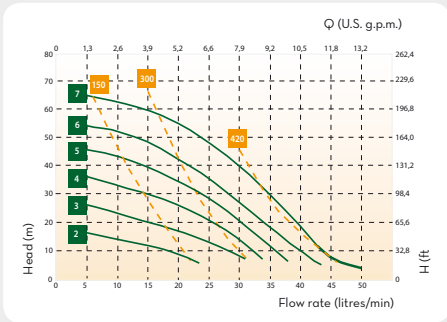

PIUSI MP 140

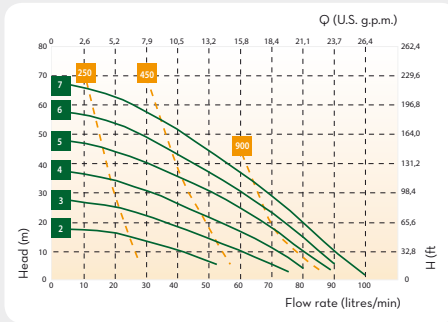

PIUSI MP 180

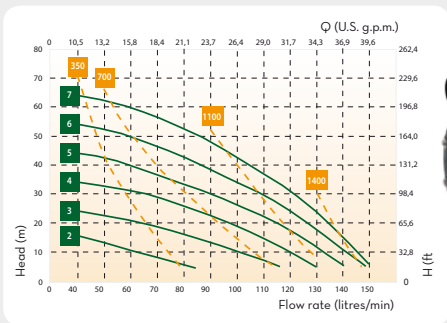

PIUSI MP 190

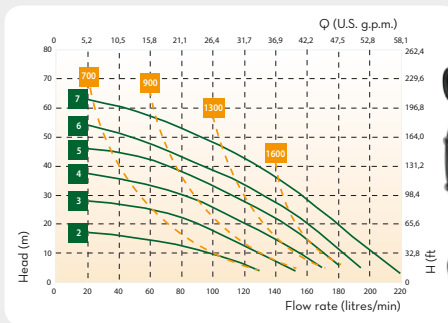

█ Air supply pressure (bar)
█ Air consumption NI/min

Our product complies with the following marking ATEX (zone 2). The Equipment user is responsible for classifying its area of use.

II	3/3	GD	c	IIB	T4
GROUP	CATEGORY	TYPE OF EXPLOSIVE ATMOSPHERE	PROTECTION METHOD	GAS CLASS	TEMPERATURE CLASS

AVAILABLE ACCESSORIES



Membrane type	Diaphragm Fluid Side/Air side	Balls	Ball seats*	O-Ring*	Intake / Delivery connection	Air connection	Max self-priming capacity	Max head**	Max air supply pressure	Max diameter of passing solid
							m	m	bar	mm
double	Hytel/PTFE	PTFE	Polypropylene	PTFE	G 1/2"f	G 3/8"f	5	70	7	4
double	Hytel/PTFE	PTFE	Polypropylene	PTFE	G 1"f	G 3/8"f	6	70	7	4
double	Hytel/PTFE	PTFE	Polypropylene	PTFE	G 1"f	G 3/8"f	5	70	7	4
double	Hytel/PTFE	PTFE	Polypropylene	PTFE	G 1"1/4 f	G 1/2"f	6	70	7	4

* On request we can provide membranes, balls, ball seats and O Rings in different materials ** The value depends on the configuration of the pump



PIUSI MA FOR Oil

EN. PIUSI MA air-operated diaphragm pumps are designed to assure the utmost reliability and highest performance levels. The sturdy central polypropylene body, the lateral half-shells and aluminium or polypropylene suction and delivery manifolds plus the use of high quality NBR diaphragms make it possible to transfer fluids with high apparent viscosities, even when contaminated with suspended solids as in the case of spent oil.

The pneumatic circuit is a guarantee of safety and the construction principle makes Piusi MA pumps particularly suitable for severe duty conditions or operation in potentially explosive atmospheres (ATEX certification for zone 2).

Piusi MP pumps are self-priming and can run dry without damage; they also allow fine tuning of speed without pressure loss.

ES. Las bombas neumáticas de membrana PIUSI MA garantizan máxima fiabilidad y altas prestaciones. El robusto cuerpo central de polipropileno, los medios cuerpos laterales de aluminio o polipropileno, junto con las membranas de alta calidad en NBR; permiten el trasiego de líquidos de alta viscosidad aparente, incluso con sólidos en suspensión como en el caso del aceite usado.

Por la seguridad del circuito neumático y por su diseño avanzado, las bombas Piusi MA están especialmente indicadas para aplicaciones severas o atmósferas potencialmente explosivas (certificación ATEX para zona 2).

Las bombas Piusi MA son autocebantes, pueden funcionar en seco sin dañarse y permiten hacer una regulación precisa de la velocidad sin pérdidas de presión.

PT. As bombas pneumáticas com membrana PIUSI MA são projetadas para garantir a máxima confiabilidade e altas prestações. O corpo central robusto em polipropileno, os semi-corpos laterais e os coletores de aspiração e descarga em alumínio ou em polipropileno e a utilização de membranas de alta qualidade em NBR permitem a passagem de líquidos com viscosidade aparentemente elevadas, mesmo na presença de partes sólidas em suspensão, como o óleo retirado.

O circuito pneumático é garantia de um funcionamento seguro e o princípio construtivo torna as bombas Piusi MA particularmente indicadas para a aplicação graves ou em ambientes potencialmente explosivos (certificação ATEX para zona 2).

As bombas Piusi MP são automáticas, podem funcionar a seco sem danos e permitem realizar uma regulação precisa da velocidade sem perdas de pressão.

DIMENSIONS

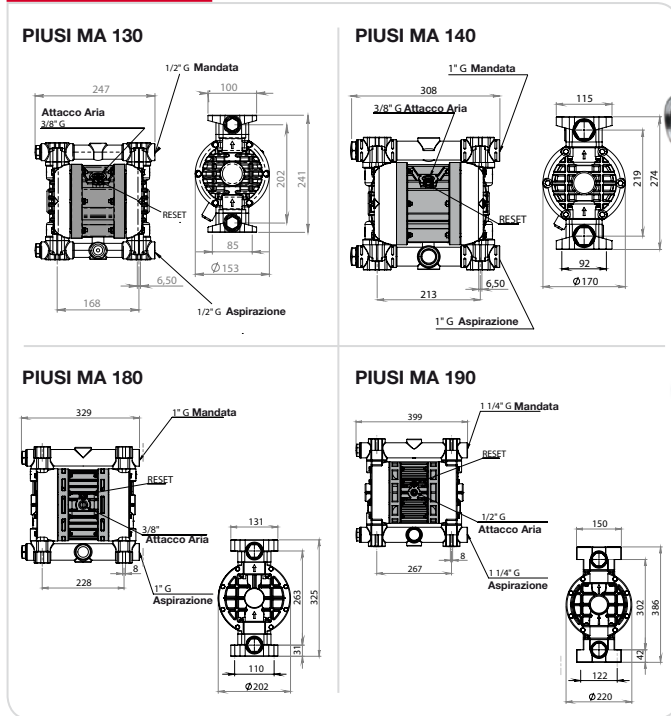

PRODUCTS' RANGE WEIGHT AND PACKAGING

Code	Weight		Packaging		
	kg	lbs	mm	inch	pcs/box
F00208A00	4	8,8	220x310x320	8,7x12,2x12,6	1
F00208P10	5	11	240x380x350	9,4x15x13,8	1
F00208A10	8,2	18,1	270x390x400	10,6x15,4x15,7	1
F00208A20	16	35,3	290x470x460	11,4x18,5x18,1	1

PRODUCTS' RANGE TECHNICAL DATA

Code	Description	Fluids	Pump Body	In/out	Flow Rate
		type			l/min
F00208A00	PIUSI MA130		Aluminium	1/2" G	50
F00208P10	PIUSI MA140		Polypropylene	1" G	100
F00208A10	PIUSI MA180		Aluminium	1" G	150
F00208A20	PIUSI MA190		Aluminium	1" 1/4" G	220



Flow-rate
up to
220 l/min
(up to 58,1 gpm)



PIUSI MA 130

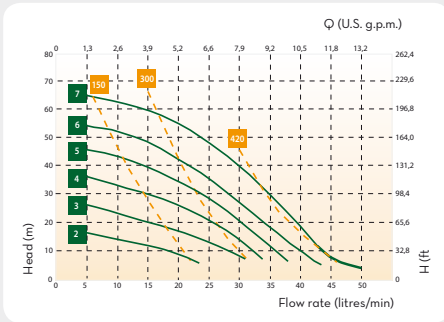

PIUSI MA 140

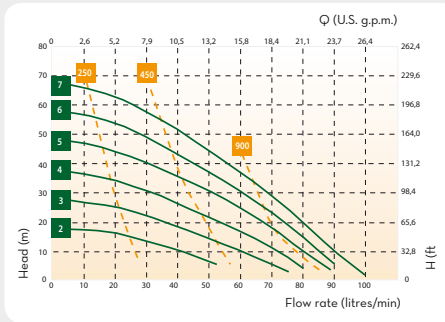

PIUSI MA 180

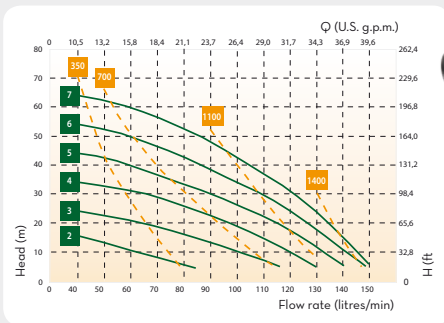

PIUSI MA 190

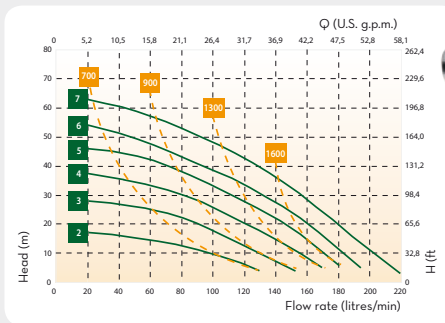

— Air supply pressure (bar)
— Air consumption NI/min

Our product complies with the following marking ATEX (zone 2). The Equipment user is responsible for classifying its area of use.

II	3/3	GD	c	IIB	T4
GROUP	CATEGORY	TYPE OF EXPLOSIVE ATMOSPHERE	PROTECTION METHOD	GAS CLASS	TEMPERATURE CLASS

AVAILABLE ACCESSORIES

K600 	K600 B/3 	K400 nozzle 	Oil Hose Reel 	Easyoil 	Pistol-One
-----------------	---------------------	------------------------	--------------------------	--------------------	-----------------------

Membrane type	Diaphragm	Balls	Ball seats*	O-Ring*	Intake / Delivery connection	Air connection	Max self-priming capacity	Max head**	Max air supply pressure	Max diameter of passing solid
							m	m	bar	mm
single	NBR	NBR	Aluminium	NBR	G 1/2"f	G 3/8"f	5	70	7	4
single	NBR	NBR	Polypropylene	NBR	G 1"f	G 3/8"f	6	70	7	4
single	NBR	NBR	PPS-V	NBR	G 1"f	G 3/8"f	5	70	7	4
single	NBR	NBR	PPS-V	NBR	G 1"1/4 f	G 1/2"f	6	70	7	4

* On request we can provide membranes, balls, ball seats and O Rings in different materials ** The value depends on the configuration of the pump



Certificati
ISO 9001 / ISO 14001



PIUSI S.p.A.
Headquarters
46029 Suzzara (Mantova) Italy
tel.+39 0376 534561
fax.+39 0376 536393
e-mail: piusi@piusi.com
www.piusi.com



PIUSI USA, Inc.
5553 Anglers Ave Suite 104
Fort Lauderdale, FL 33312
tel.: 954 584 1552
fax.: 954 584 1554
Email: piusiusa@piusiusa.com
www.piusiusa.com

**REQUIRE ONLY
THE ORIGINAL PIUSI
PRODUCTS**

